

ITEM	DN	L	D	D1	D2	f	b	Z- ϕ d	H
4	500	1100	715	650	610	4	36	20-33	1100
3	800	1500	1025	950	900	5	41	24-39	1700

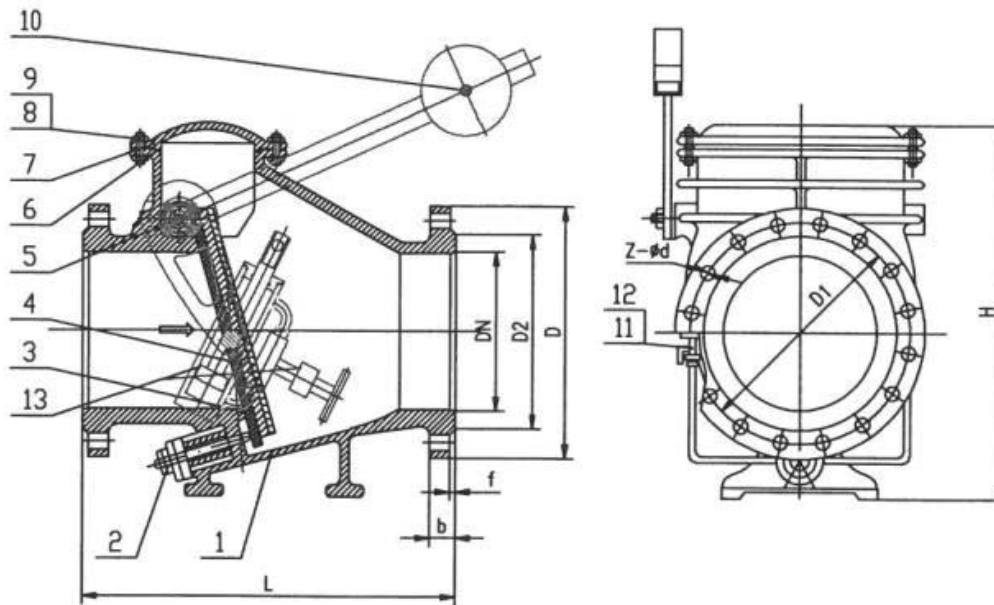

Item	Part Name	Material
1	Body	GGG40
2	Adjusting nut	SS304
3	Seat	GGG40
4	Disc	GGG40+NBR
5	Pin	SS410
6	Seal gasket	NBR
7	Bonnet	GGG40
8	Bolt	A193 B7
9	Nut	A194 2H
10	Counter weight	GGG40
11	Regulating valve	ASSEMBLY
12	Oil cylinder	ASSEMBLY
13	Hydraulic cylinder	ASSEMBLY

PN16			
Test Pre- ssure	Shell Test	1.5	MPa
	Back Seal Test	-	
	Seal Test	1.1	
	Air Test	-	
SuitableTemp.	-29~80 °C		
Suitable Medium	Sewage water, Steam, Oil etc.		
Design	ASME B16.34		
Face to face	EN 558		
Inspection	EN 12266		
Flanged ends	EN 1092-1		



FAMAT
ENGINEERED VALVES

CHECK VALVE